

# BGP IN THE MULTI-CLOUD UNDERLAY

RESILIENCE AND SYMMETRY  
BETWEEN  
ON-PREM AND PUBLIC CLOUD

ITNOG 10

Bologna, 21-04-2026

# WHO I AM

---



Hi there. Here's  
**Carlo.**



Chief Network Architect & Sr Managing Consultant @ Kyndryl

Certified ICT Trainer

Cisco CCIE EI | Tech Blogger & Public Speaker

## Key Focus Areas:

Cloud Networking & Security | Network Automation & Observability | IPv6 |  
Segment Routing | BGP Security | DevOps | AI



[/cplciciriello](#)

# AGENDA

---

- Connectivity to Public Cloud
- Azure ExpressRoute overview
- AWS Direct Connect overview
- Google Cloud Interconnect overview

# CONNECTIVITY TO PUBLIC CLOUD

# INTERNET-BASED VPN AND DEDICATED PRIVATE CLOUD CONNECTIVITY



## VPN

Encrypted Tunnels  
over the  
Public Internet

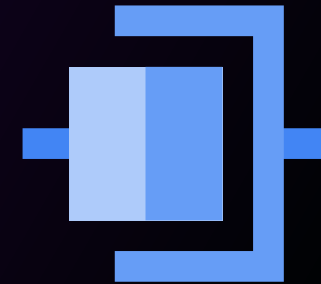

## DEDICATED PRIVATE CONNECTION

Dedicated  
Connection to  
Public CSP

# AZURE EXPRESSROUTE OVERVIEW

# HIGH AVAILABILITY PATTERNS FOR EXPRESSROUTE

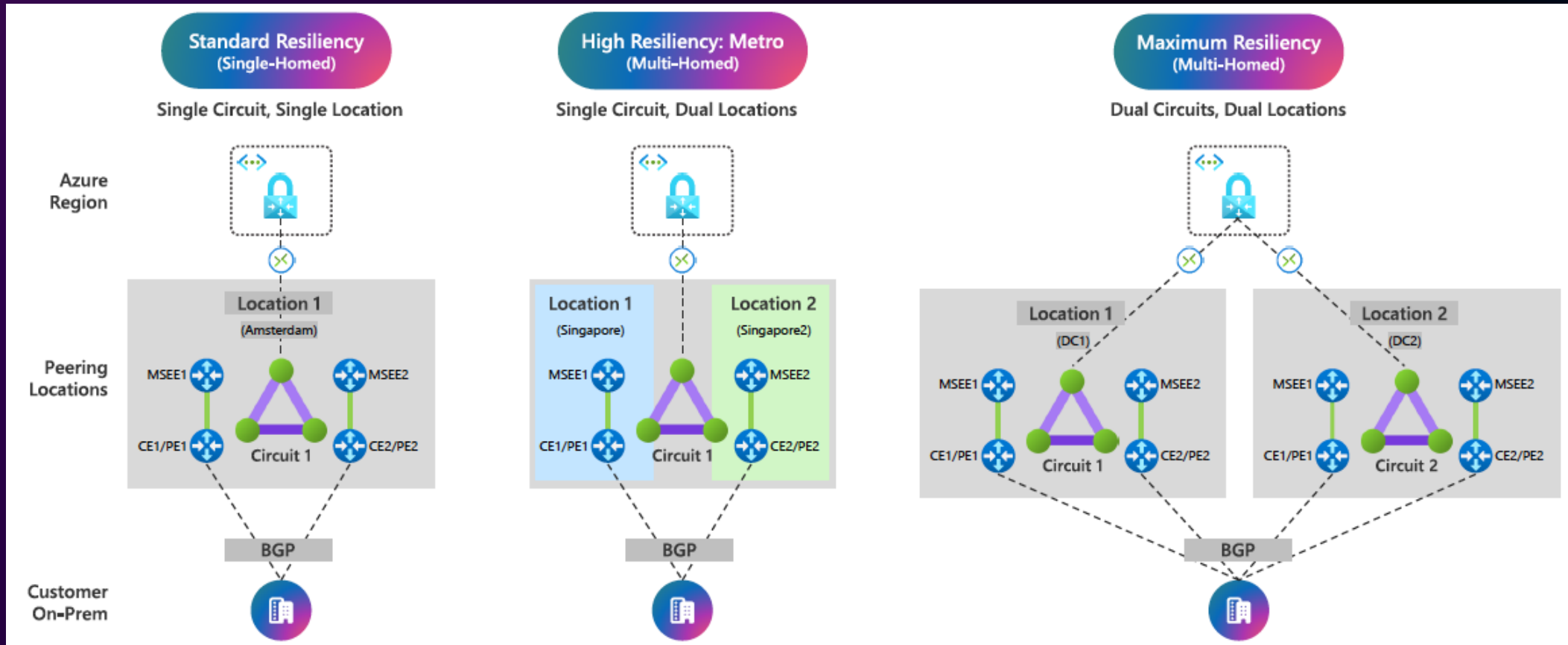

MSEE = Microsoft Enterprise Edge device  
CE = Customer Edge device  
PE = Provider Edge device

# AWS DIRECT CONNECT OVERVIEW

# HIGH AVAILABILITY PATTERNS FOR DIRECT CONNECT: BASIC RESILIENCY

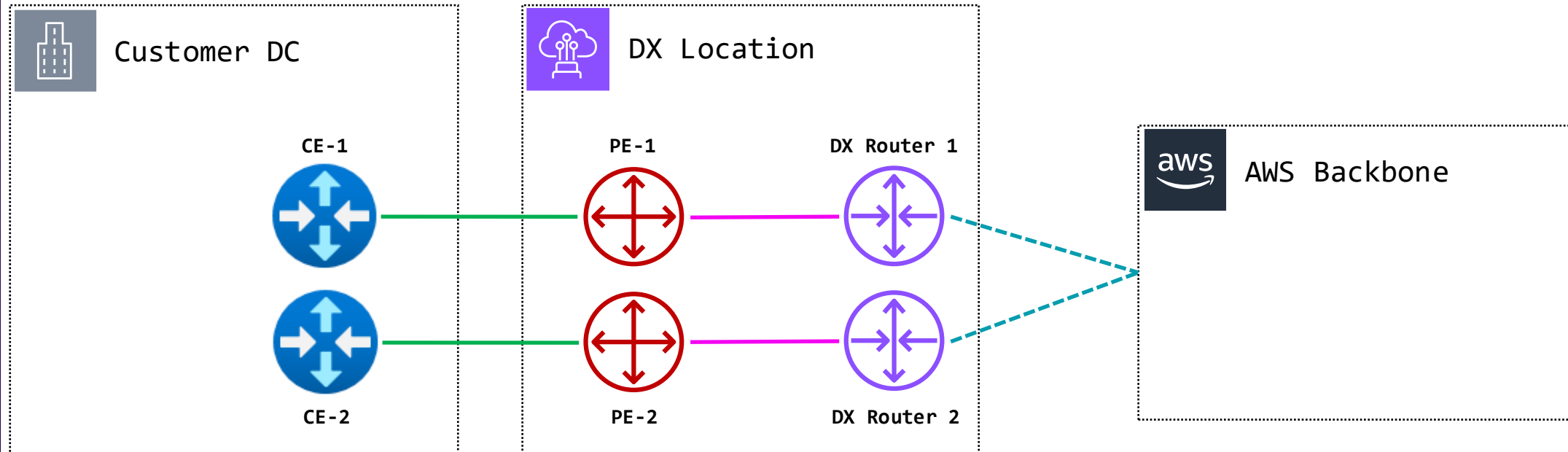

# HIGH AVAILABILITY PATTERNS FOR DIRECT CONNECT: HIGH RESILIENCY

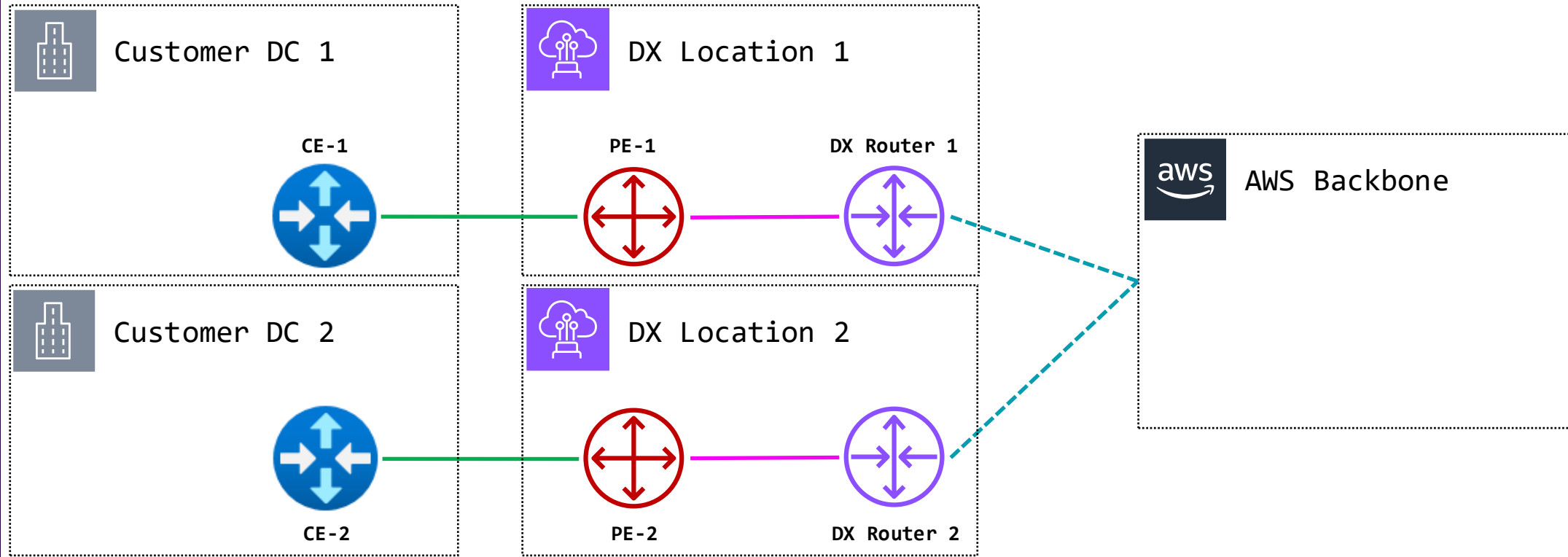

# HIGH AVAILABILITY PATTERNS FOR DIRECT CONNECT: MAXIMUM RESILIENCY

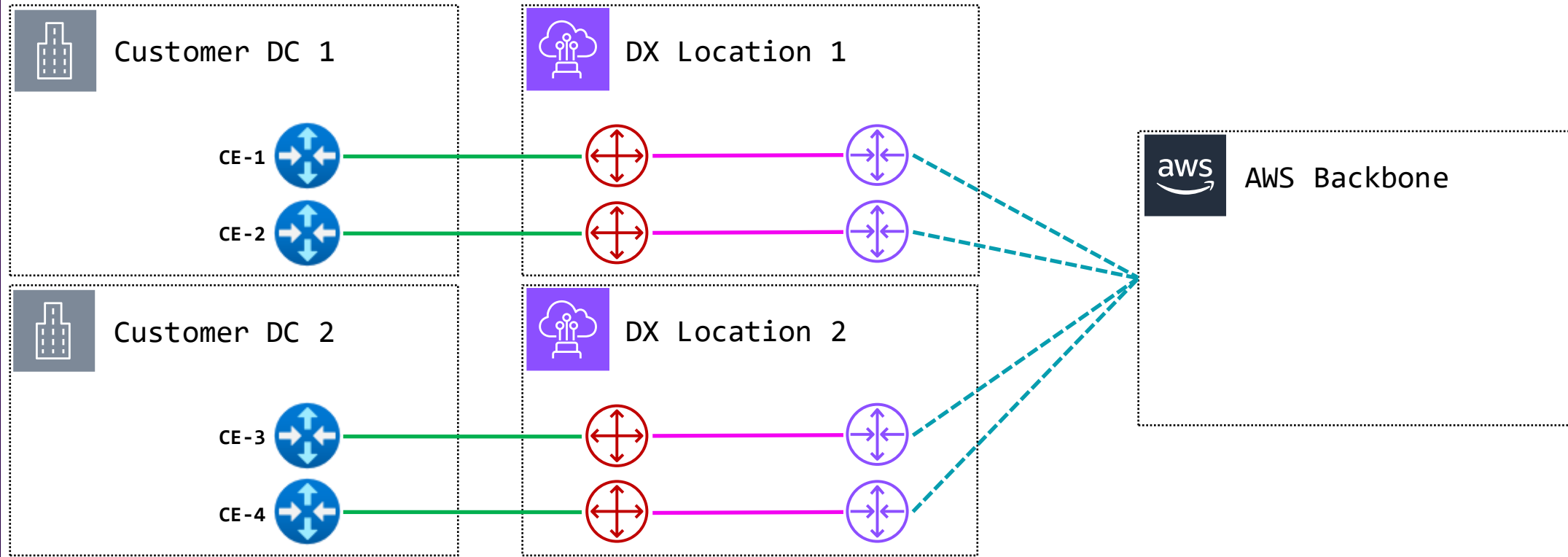

# GOOGLE CLOUD INTERCONNECT OVERVIEW

# DEDICATED INTERCONNECT RESILIENCY TOPOLOGY COMPARISON: 99.9% VS 99.99%



**99.9% AVAILABILITY**

# DEDICATED INTERCONNECT RESILIENCY TOPOLOGY COMPARISON: 99.9% VS 99.99%



**99.99% AVAILABILITY**

# PARTNER INTERCONNECT RESILIENCY TOPOLOGY COMPARISON: 99.9% VS 99.99%



**99.9% AVAILABILITY USING LAYER 2**

# PARTNER INTERCONNECT RESILIENCY TOPOLOGY COMPARISON: 99.9% VS 99.99%

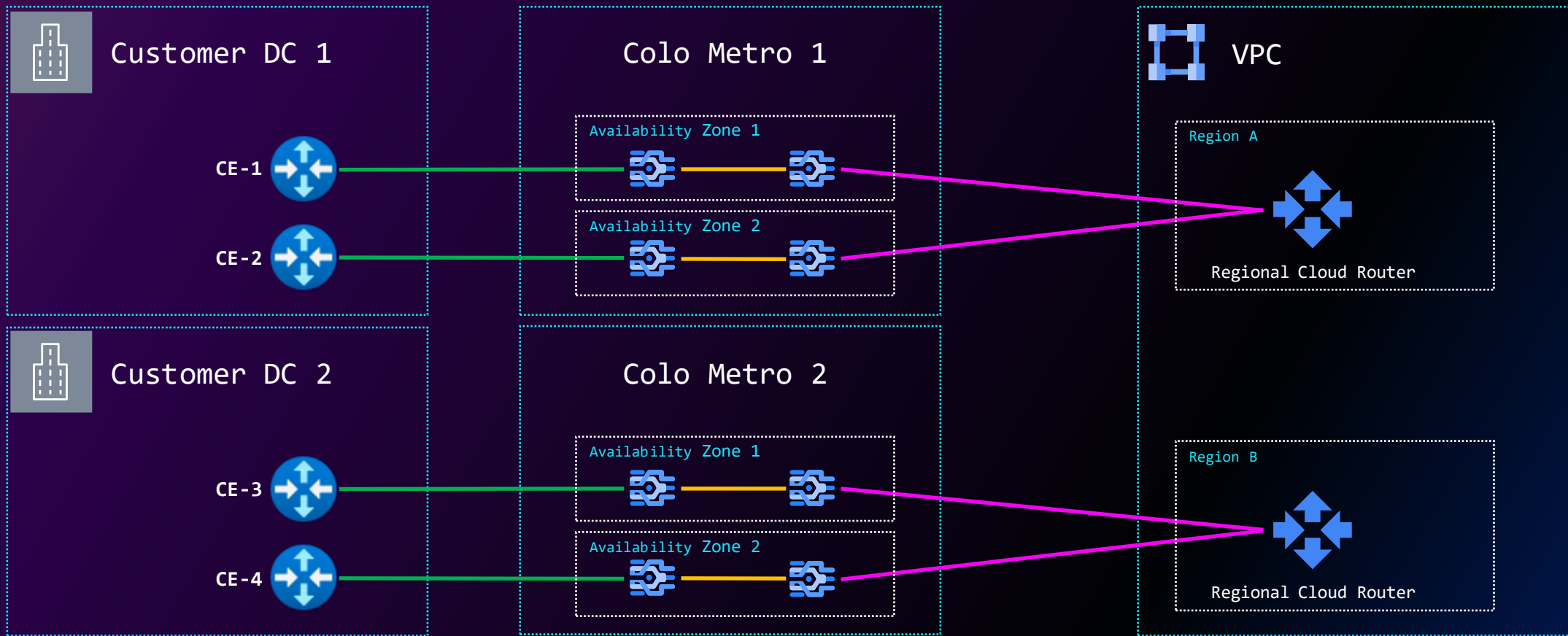

**99.99% AVAILABILITY USING LAYER 2**

# PARTNER INTERCONNECT RESILIENCY TOPOLOGY COMPARISON: 99.9% VS 99.99%



**99.9% AVAILABILITY USING LAYER 3**

# PARTNER INTERCONNECT RESILIENCY TOPOLOGY COMPARISON: 99.9% VS 99.99%

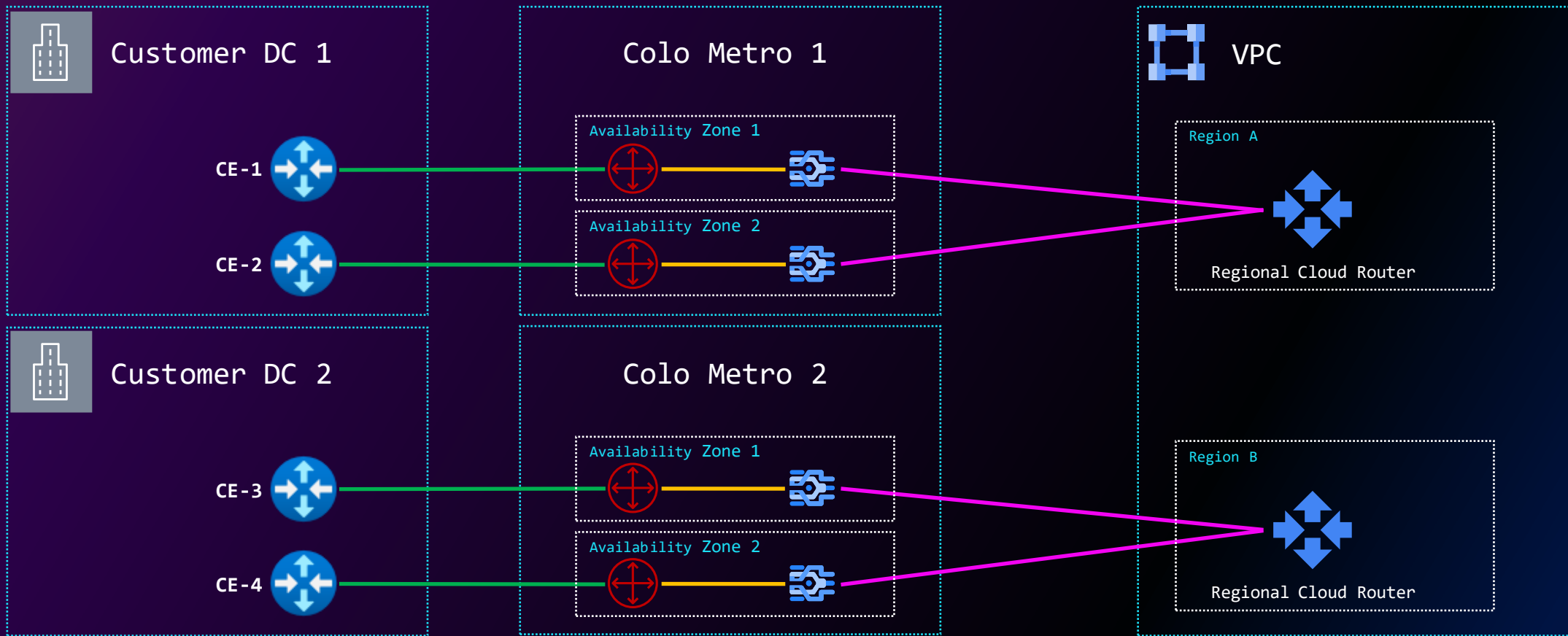

**99.99% AVAILABILITY USING LAYER 3**



THANK YOU

ITNOG 10

Bologna, 21-04-2026